

FEATURED ALUM-A-LIFT EXPANDING MANDREL LIFT WITH SWIVELING CROSSBAR

PROJECT 35228



MODEL A1500CSLR-126

FEATURING Powered Expanding Mandrel, Powered Lateral Shuttle, Powered 90° Rotation, Swiveling Crossbar with J-Hooks, V-Trough Cart

HANDLING 300 lb [136 kg] Rolls

DETAILS This 11' 4" Alum-a-Lift has been specifically designed to achieve the required lower and upper height limits set by a client, allowing a removable swiveling crossbar attachment to reach a height of 100 inches. This feature is essential for installing rolls with a pre-installed shaft into various machinery. The swiveling crossbar, equipped with hooks, can be connected to the mandrel to manage rolls weighing up to 300 pounds and includes a side-to-side lateral shuttle for precise roll positioning. The expanding mandrel is provided for standard roll applications. To complement this expanding mandrel lift, a v-trough alum-a-dolly is included for staging the rolls.

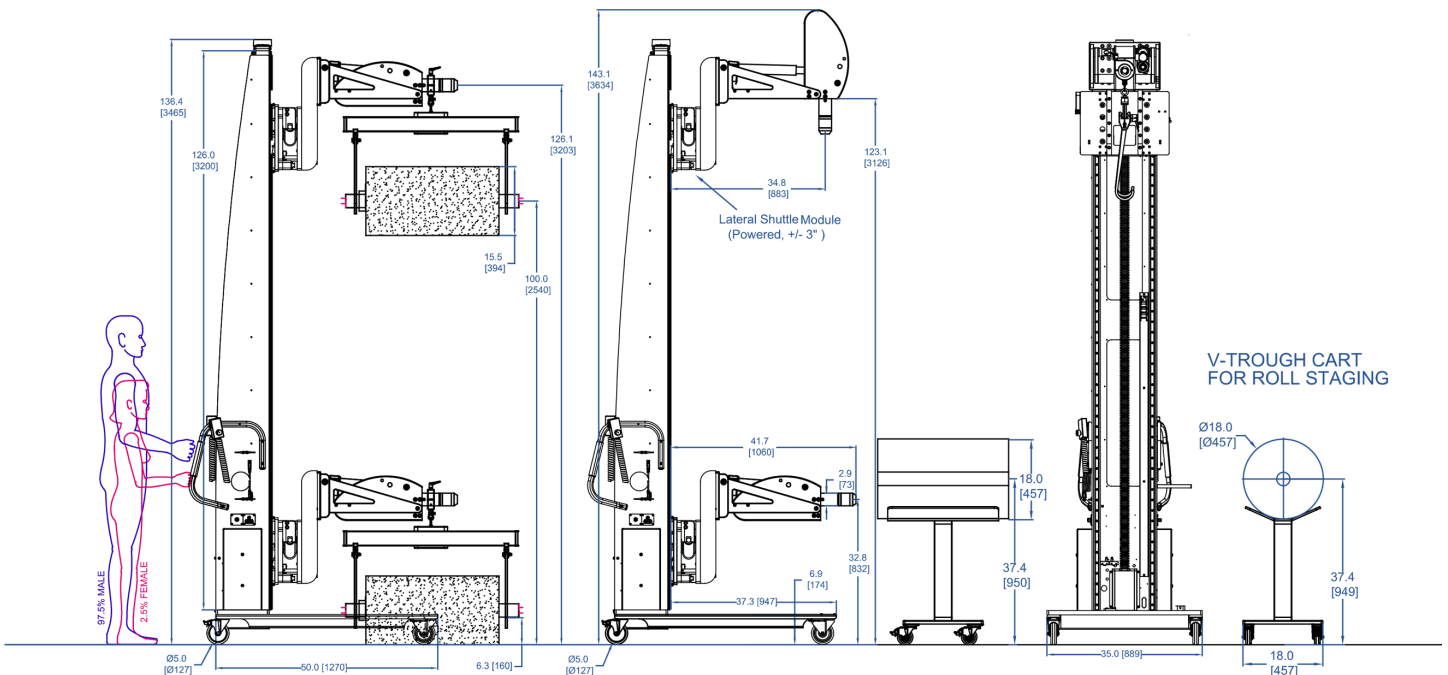

alum-a-lift

13941 Veterans Memorial Hwy
Winston, GA 30187 USA
+1 770 489 0328

GET STARTED AT ALUM-A-LIFT.COM