

# FEATURED ALUM-A-LIFT CLEANROOM CLAMP LIFT FOR OPTICAL FIBER PREFORMS

## PROJECT 35074



**MODEL** B350CRCS-72

**FEATURING** Cleanroom Class 100, Powered 360° Rotation, Powered Precision Clamp w/ Clamp Force Limiter, Quick-Exchange Battery System

**HANDLING** 110 lb [50 kg] Preforms

**DETAILS** A technology company was looking for a cleanroom compliant (class 100) lifting solution to support optical fiber preforms of various sizes while operators apply a potting compound, then move into storage for curing. This Alum-a-Lift includes a precision clamp to grip the preforms at each end and hold horizontally to allow for preparatory work. The clamp can freely rotate 360°, and can be locked in any position to prevent mishandling or damage to the preform. Additionally, this cleanroom clamp lift comes with a quick-exchange battery system and offline charging for continues use of the lift over multiple shifts.

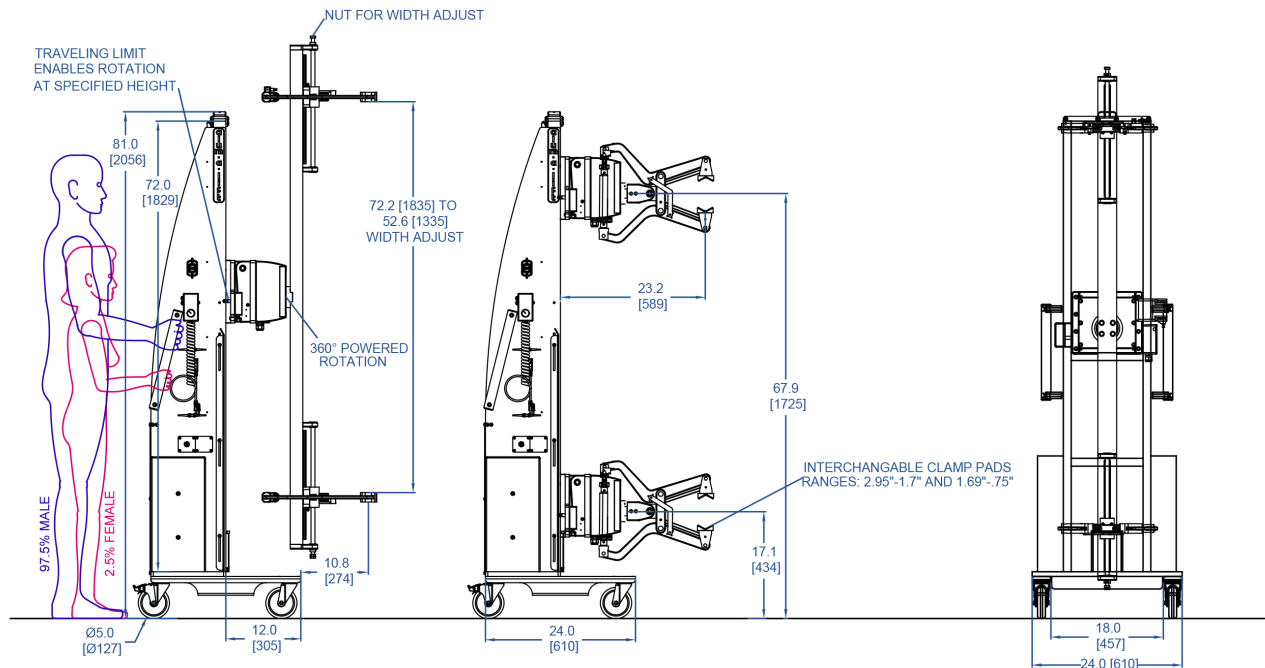

**alum-a-lift**

13941 Veterans Memorial Hwy  
Winston, GA 30187 USA  
+1 770 489 0328

**GET STARTED AT ALUM-A-LIFT.COM**