

FEATURED ALUM-A-LIFT ROTATING GRIPPER LIFT FOR PNEUMATIC TUBE SYSTEMS

PROJECT 34616



MODEL L200CS-72

FEATURING Manual Rotation Device, Manual Clamp w/ Wrists, Motor Speed Controller

HANDLING 35 lb [15 kg] Steel Tubes

DETAILS A logistics automation company was interested in obtaining a lift assist for an application installing bent steel tubes into a machine housing. The tubes used vary in length and diameter with a maximum weight of 35 lb. In their operation, lifting the tubes are oriented vertically, then rotated 90 degrees to install into the housing.

This rotating gripper lift features manual wrists which allow the gripper pads to rotate front to back and a manual side to side rotation module for orienting the tubes from a vertical to horizontal position. Combined, these features allow the user to lift tubes from the geometric center and rotate horizontally for installation, making it an essential tool for building pneumatic tube systems.

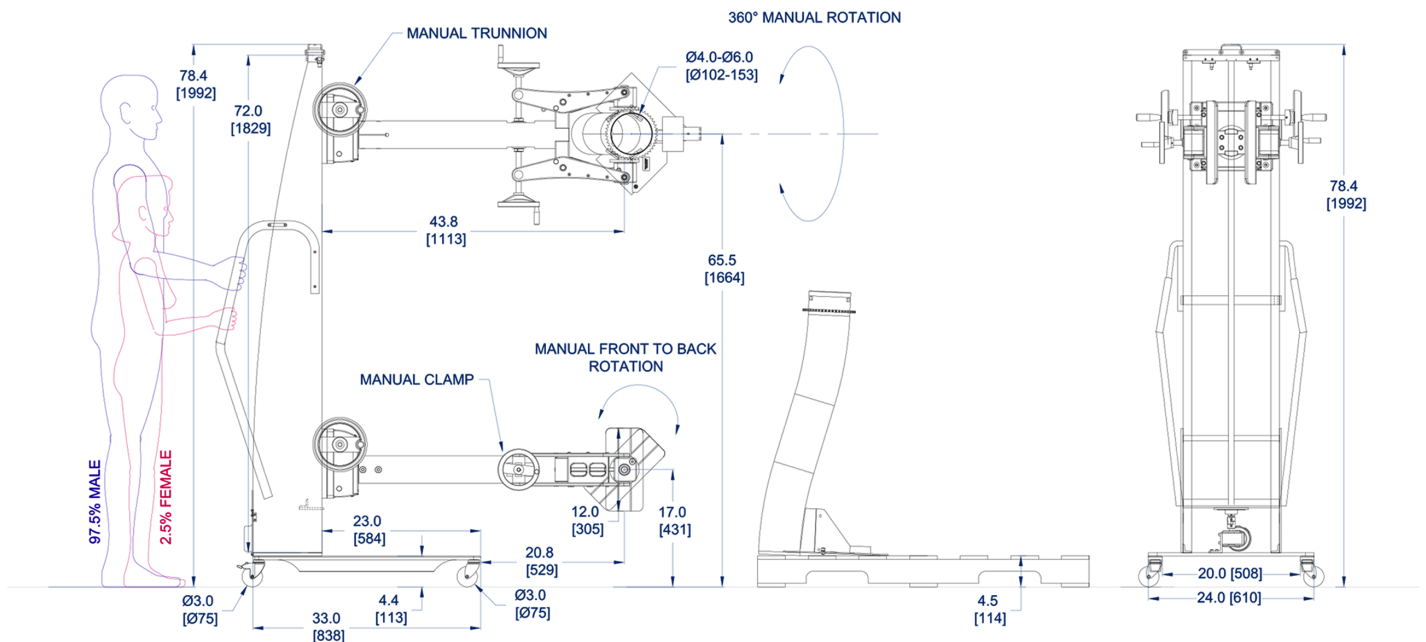

alum-a-lift

13941 Veterans Memorial Hwy
Winston, GA 30187 USA
+1 770 489 0328

GET STARTED AT ALUM-A-LIFT.COM