

FEATURED ALUM-A-LIFT  
 COMPACT HEAVY DUTY LIFT FOR CLASS 2 DIV 2 ENVIRONMENTS

PROJECT  
**34618**

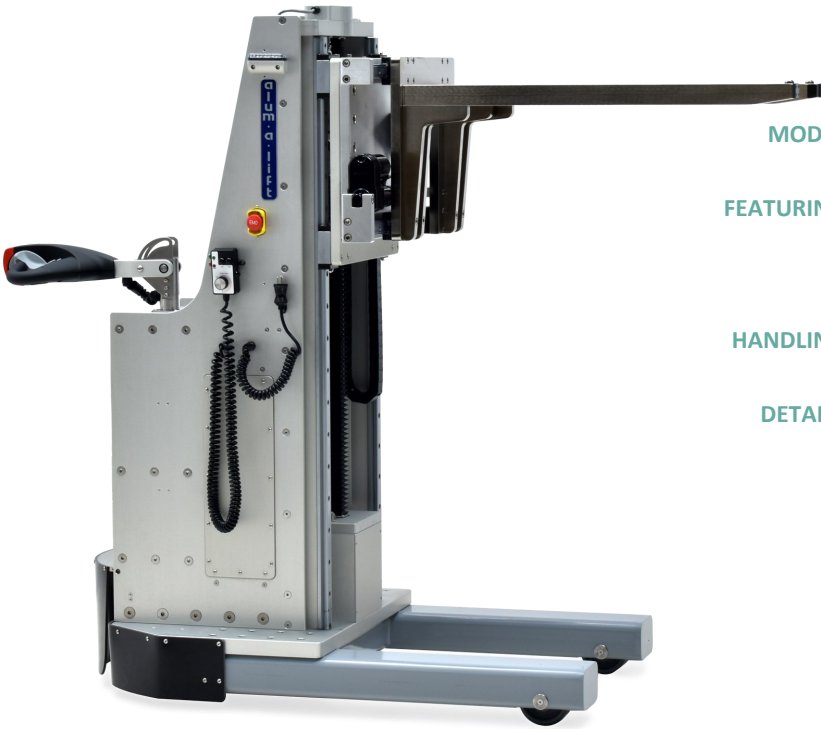

**MODEL** A3500CSLRPDEE-60

**FEATURING** Powered Drive Wheel, Heavy Duty Fork Set, Folding 90° Drive Handle, Powered Lateral Shuttle, Safety Overload Module w/Load/Obstacle Sensing

**HANDLING** 1,125 lb [510 kg] Roller Assemblies

**DETAILS** This compact lift was designed for a candy manufacturer production line with very narrow aisles where they needed to lift, remove, and reinstall heavy roller assemblies into their machinery and required NEC Class 2 Div 2 compatibility, making a standard forklift impractical. Alum-a-Lift customized a shortened lift body for maximum clearance with a 90° folding drive handle to allow even more compactness if needed. This lift also includes a heavy duty shuttling fork set with cutouts to clear features on the load, obstacle sensing capabilities, and an overload safety module in case of an overload.

