

FEATURED ALUM-A-LIFT  
AEROSPACE GROUND SUPPORT WORK POSITIONER LIFT

PROJECT  
**34182**

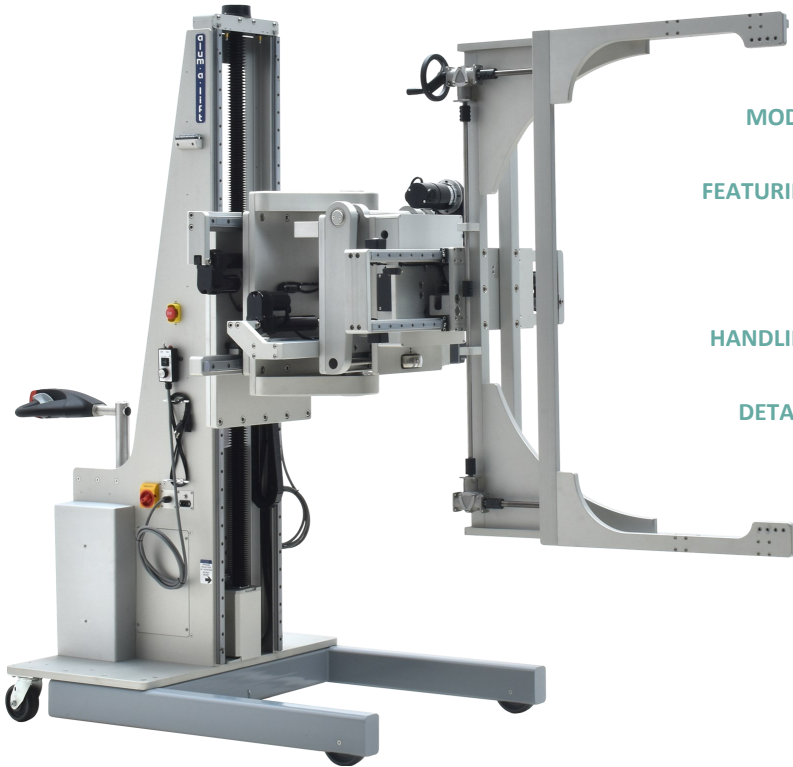

**MODEL** A1500CSLRPD-84

**FEATURING** Install & Workstation End-effector, Powered Tilt, Powered Drive Wheel, Powered 360° Rotation, Powered Lateral Shuttle, Powered Yaw Module, Powered Vertical Shuttle, Obstacle Sensing

**HANDLING** 280 lb [127 kg] Aerospace Subassemblies

**DETAILS** This ground support work positioner was built for an aerospace company to install heavy subassemblies and to function as a workstation that would rotate flight hardware to provide more favorable worker access. Having manipulation in all 6 degrees of freedom, this Alum-a-Lift allows for accurate positioning of components and features load and obstacle sensing capabilities to eliminate the risk of damaging sensitive equipment during travel.

