

FEATURED ALUM-A-LIFT ROLL HANDLING LIFT WITH POWERED CLAMP AND TRUNION

PROJECT 32640



MODEL A800CS-72

FEATURING Powered Clamp, Powered Side-to-Side Rotation, Manual Forward Rotation, Anti-Telescoping Device

HANDLING 275 lb [125 kg] Rolls

DETAILS This lift was designed for a personal care manufacturer that needed a material handling solution to handle large, heavy rolls of labels used for their FDA-regulated medical device. Alum-a-Lift offered a solution that securely grips the roll and facilitates rotation about 2 axis. The manual wrist enables forward rotation, while the trunion allows side-to-side rotations. This lift eliminates the need for manual lifting by grabbing rolls from a pallet and loading them onto the machine. For rolls that “telescope” or are made of slick materials, the anti-telescoping device ensures a secure grip on both the core and exterior to keep the roll from falling apart/sliding down due to gravity thus preserving the roll’s integrity throughout the handling process.

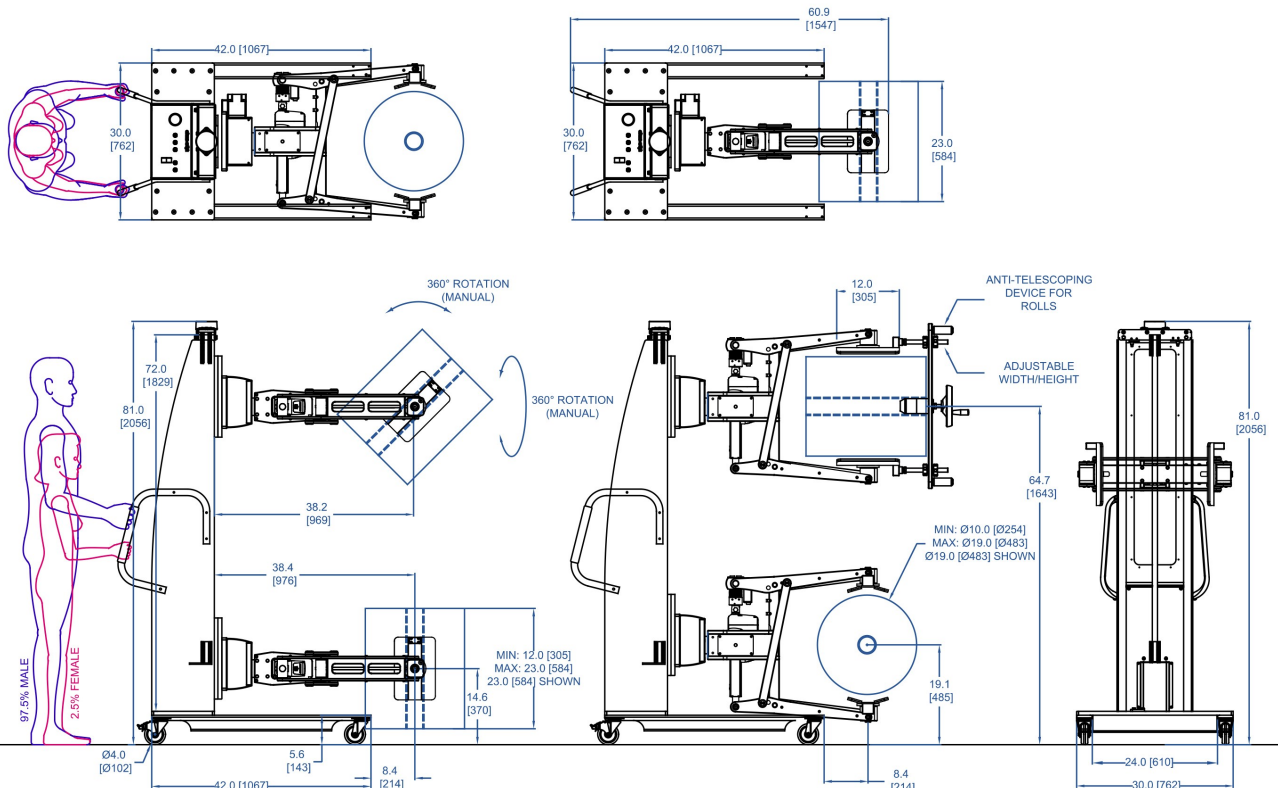

alum-a-lift

13941 Veterans Memorial Hwy
Winston, GA 30187 USA
+1 770 489 0328

GET STARTED AT ALUM-A-LIFT.COM