

# FEATURED ALUM-A-LIFT TELESCOPING BOOM LIFT FOR LASER OPTICAL COMPONENTS

## PROJECT 33282



**MODEL** A800CRSLR-72

**FEATURING** Swivel Hoist Ring, Manual Telescoping Boom with Lock, Obstacle and Overload Sensing, Active Lifting Speed Adjustment, Floor Brakes, ISO 5 (Class 100) Cleanroom Rated, SEMI S2, CE Compliant

**HANDLING** 150 lb [68 kg] Laser Optical Components

**DETAILS** This lift is designed to service various items in a new tool for a leading semiconductor and display equipment company. The telescoping boom shuttles in and out allowing a more compact footprint and the leveling pads are compatible with the flooring typically found in semi cleanrooms. Our team worked closely with the customer's engineering group to develop a complete solution tailored to meet the exacting requirements needed for formal NRTL (Nationally Recognized Testing Laboratory) testing to SEMI S2.

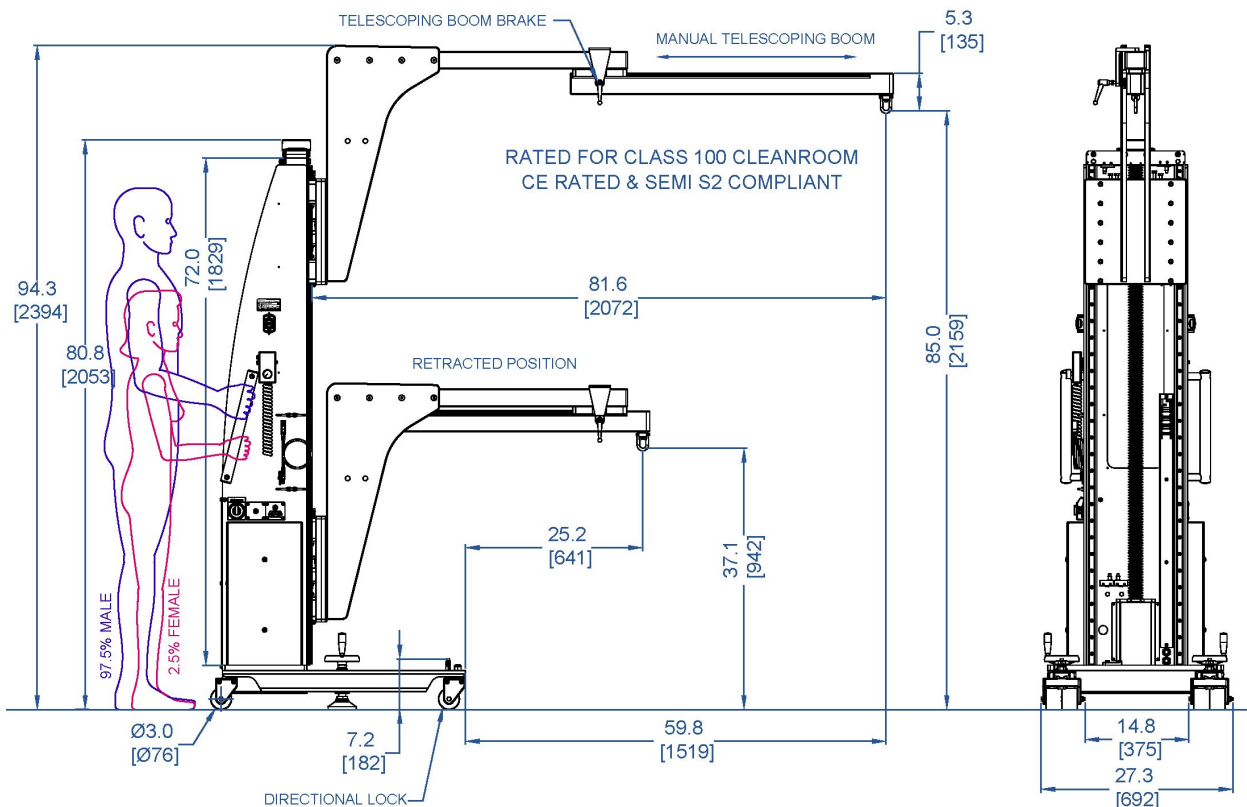

**alum-a-lift**

13941 Veterans Memorial Hwy  
Winston, GA 30187 USA  
+1 770 489 0328

GET STARTED AT [ALUM-A-LIFT.COM](http://ALUM-A-LIFT.COM)