

# FEATURED ALUM-A-LIFT UNIVERSAL DRUM LIFTER FOR METAL AND PLASTIC DRUMS

## PROJECT 33375



**MODEL** A800CRCS-69

**FEATURING** Powered Clamp, Pivoting Clamp Pads, Powered Rotation, Class 1000 (ISO 6) Cleanroom Compatibility

**HANDLING** 330 lb [150 kg] Drums

**DETAILS** This universal aluminum, cleanroom compliant lift enables safe single-operator lifting, manipulation, and pouring of drum contents. A heavy duty clamp with pivoting, swappable clamp pads whose height can also be easily adjusted, allows compatibility with both straight sided and tapered barrels as well as multiple types of drums. This drum lifter was designed with a small footprint to allow compatibility with the process's tight space clearances. Additionally, the selection switch ensures you can lift the correct drum each time.

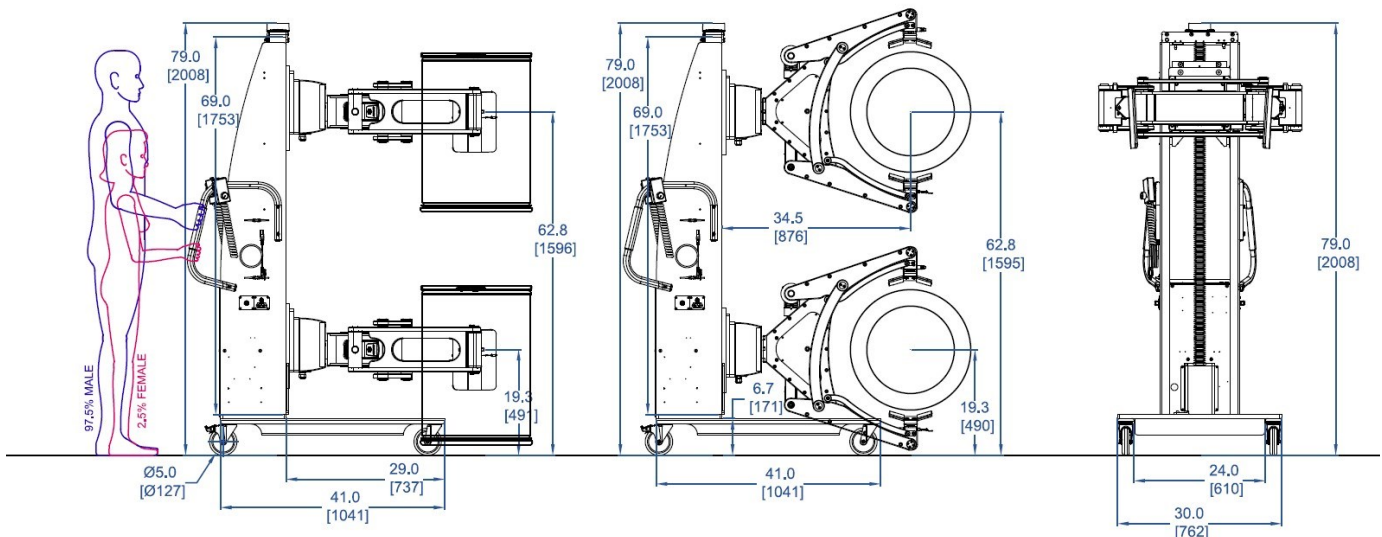
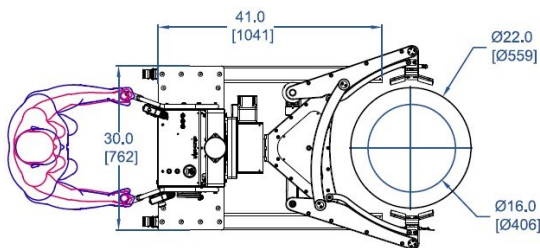

**alum-a-lift**

13941 Veterans Memorial Hwy  
Winston, GA 30187 USA  
+1 770 489 0328

GET STARTED AT [ALUM-A-LIFT.COM](http://ALUM-A-LIFT.COM)