

FEATURED ALUM-A-LIFT ROLL HANDLING LIFT WITH EXPANDING CORE GRIPPER

PROJECT 33271



MODEL A800CS-72

FEATURING 90° Rotating Expanding Mandrel, Tilt-Up Safety, Safe-to-Lift Indicator Light, Quick-exchange Mandrel Tips

HANDLING 400 lb [181 kg] Rolls

DETAILS Rolls of material are often used in manufacturing settings and sometimes those rolls cannot be handled from the exterior of the roll. When this is the case the expanding mandrel lift is the perfect solution. This lift engages the roll from the core using a powered, non-marring rubber gripper. This lift features exchangeable $\varnothing 3''$ and $\varnothing 6''$ tips as well as powered 90° front-to back rotation. Safety features include a "safe-to-lift" light, indicating that the correct gripping force has been achieved to lift the roll, as well as overtravel protection when lowering.

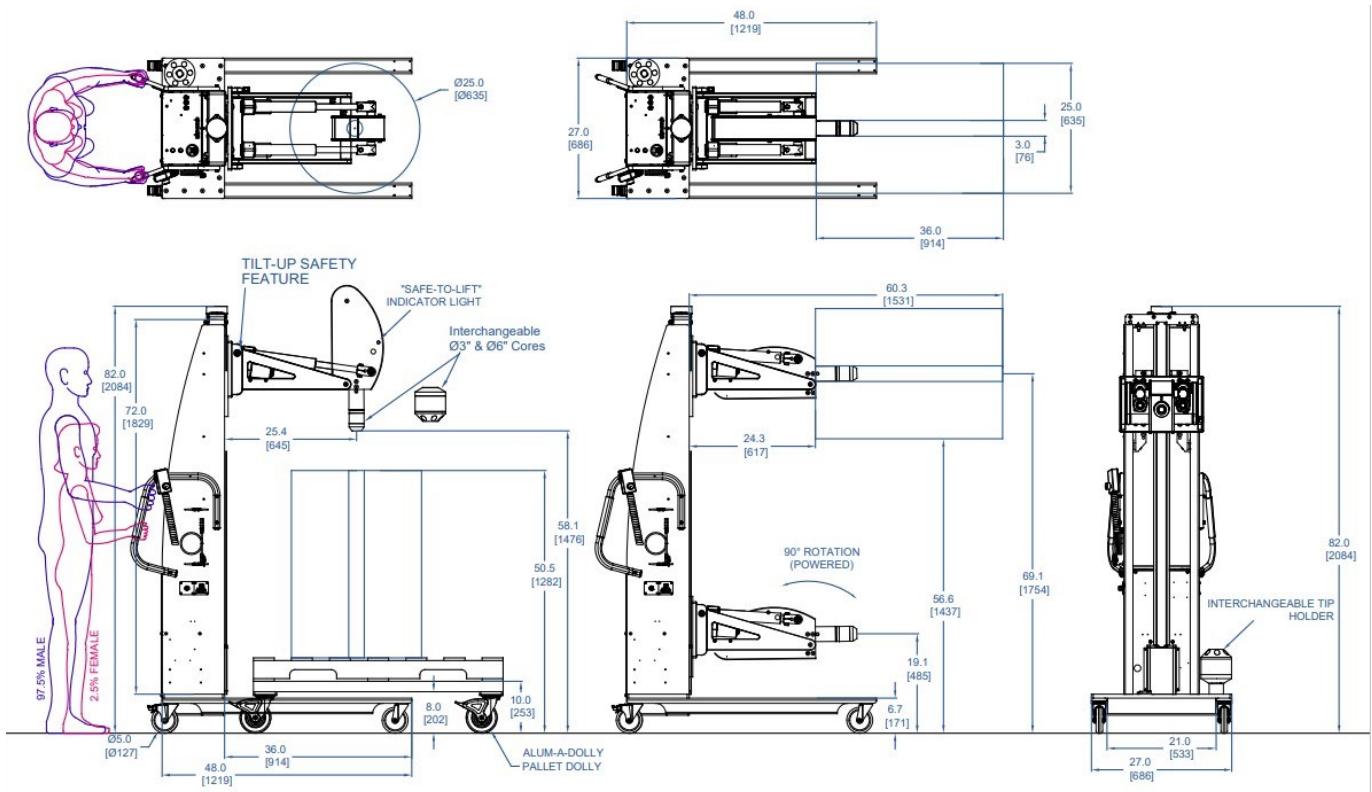

alum-a-lift

13941 Veterans Memorial Hwy
Winston, GA 30187 USA
+1 770 489 0328

GET STARTED AT ALUM-A-LIFT.COM