

FEATURED ALUM-A-LIFT SELF-PROPELLED PORTABLE CLEANROOM HOIST

PROJECT 31354



MODEL C2500CRSLRPD-96

FEATURING Folding Boom with Swivel Hoist Ring, Latching Safety Hook, Powered Lateral Shuttle, Class 1,000 (ISO 6) Cleanroom Rating, Powered Drive

HANDLING 1000 lb. [454 kg] Electronic Components

DETAILS This mobile, high capacity, cleanroom rated lift was built to support the manufacture of electronic components. The 2 speed power drive handle allows the operator to easily navigate the tight space of a clean room environment, and the powered lateral shuttle aids with alignment. When not in use, the boom conveniently folds up for compact storage.

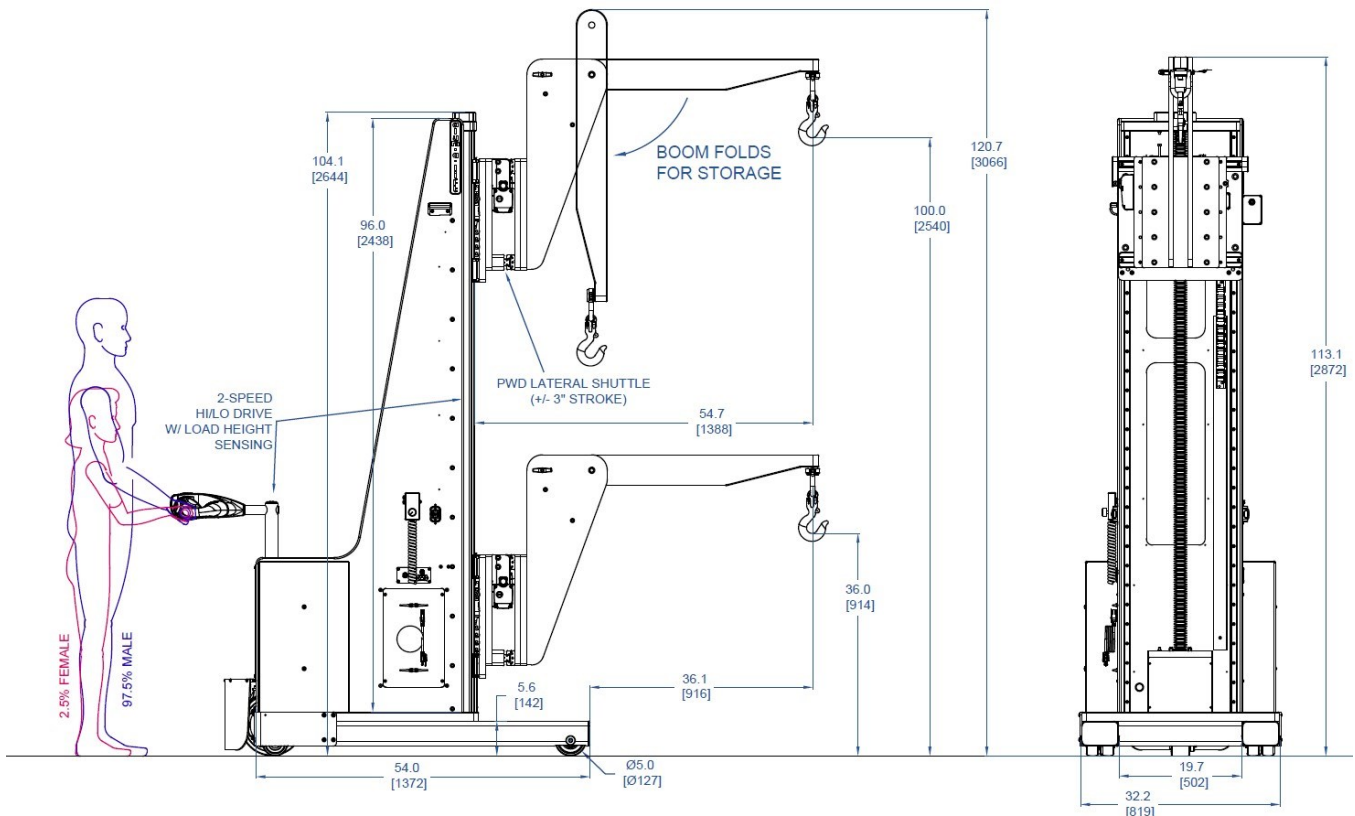

alum-a-lift

13941 Veterans Memorial Hwy
Winston, GA 30187 USA
+1 770 489 0328

GET STARTED AT ALUM-A-LIFT.COM