

FEATURED ALUM-A-LIFT SELF-PROPELLED MEDICAL FILTER CABINET LIFT

PROJECT 30586



MODEL A800CLRPD-72

FEATURING Application-specific Clamp Pads, Extended-Reach clamp, Powered Front-to-Back Rotation

HANDLING 135 lb. [61 kg] Cabinets

DETAILS A medical equipment manufacturer needed to position various cabinets for final assembly and packaging. An extended-reach clamp was chosen to grip and lift the cabinets, and powered front-to-back rotation allows the cabinet to be placed in the correct orientation on a work bench for adding components. Cutouts on the clamp pads avoid damage to the gauges and switches on the exterior of the cabinet. The lift holds the cabinets clear of the legs, allowing it to be placed directly on a pallet for shipping to the end user.

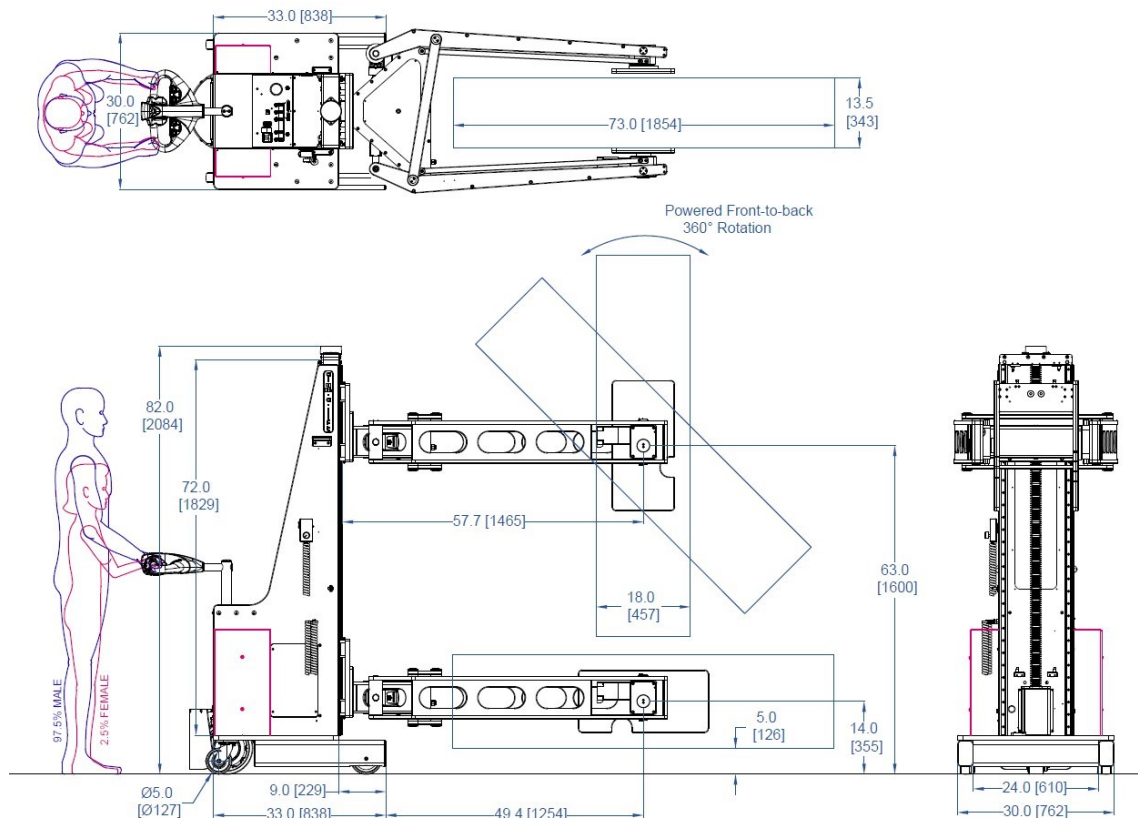

alum-a-lift

13941 Veterans Memorial Hwy
Winston, GA 30187 USA
+1 770 489 0328

GET STARTED AT ALUM-A-LIFT.COM