

FEATURED ALUM-A-LIFT MULTI-PURPOSE LIFT FOR SEMICONDUCTOR WAFER FAB

PROJECT 30098

MODEL S1000CRCS-70/63

FEATURING Articulated Arm, Load & Obstacle Sensing, Telescoping Mast, Deployable Outriggers, Powered Drive, ISO 5 (Class 100) Cleanroom, SEMI & CE rated

HANDLING 300 lb [136 kg] Semiconductor Components

DETAILS This multi-purpose lift is designed specifically for servicing production tools in a wafer fab. Featuring an articulated arm and a large compliment of end-effectors, the lift can handle pumps, valves, power supplies and other tooling. The lift's compact design and powered drive allow for easy navigation in tight spaces. The telescoping mast reaches an elevated height while manually deployed outriggers ensure stability while handling large loads at an extended reach. This system eliminates risky handling and reduces costly equipment downtime.

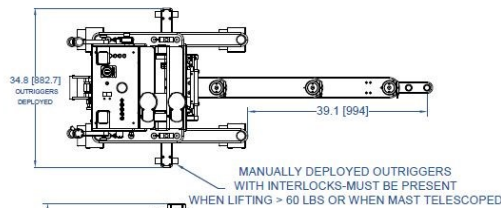
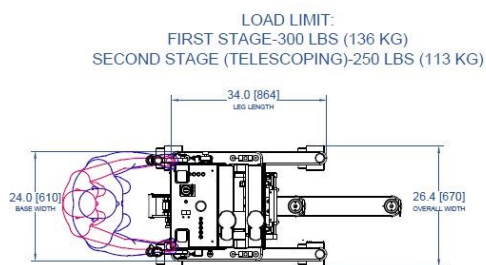

SEMI-LIFT

CLASS 100 CLEANROOM
SEMI S2 & S8 COMPLIANT/ CE RATED

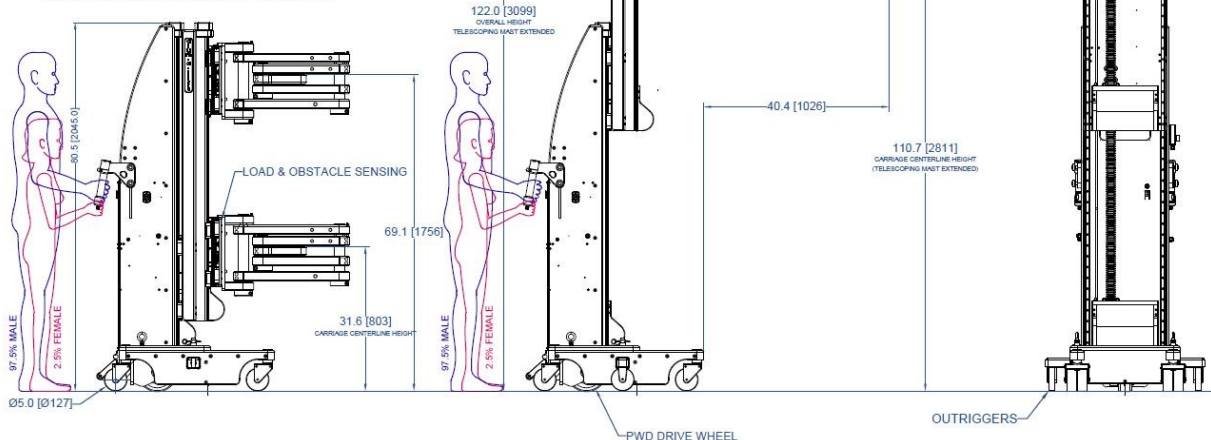

alum-a-lift

13941 Veterans Memorial Hwy
Winston, GA 30187 USA
+1 770 489 0328

GET STARTED AT ALUM-A-LIFT.COM