

FEATURED ALUM-A-LIFT PHARMACEUTICAL DRUM DUMPER FOR IBC LOADING

PROJECT 27294

MODEL A1500SSPDWDT-72/72

FEATURING Powered Clamp, Powered Rotation, Powered Shuttle, Dual Lifting Stage, Stainless Steel 304 Construction

HANDLING 400 lb [180 kg] Drums and Barrels

DETAILS Replacing several floor-mounted material handling systems, this mobile lift dispenses powder or granular materials into Intermediate Bulk Containers (IBC's) for blending. This device can raise a floor bound drum and inverting it above an IBC that is on a weigh scale. The dual lifting stage of this lift allows for transit through standard height doors to service multiple rooms. The front-to-back shuttle decreases the lifts footprint during operations that do not require the long reach. A steerable powered drive wheel makes the lift self-propelled, eliminating any ergonomic concerns due to push/pull forces.

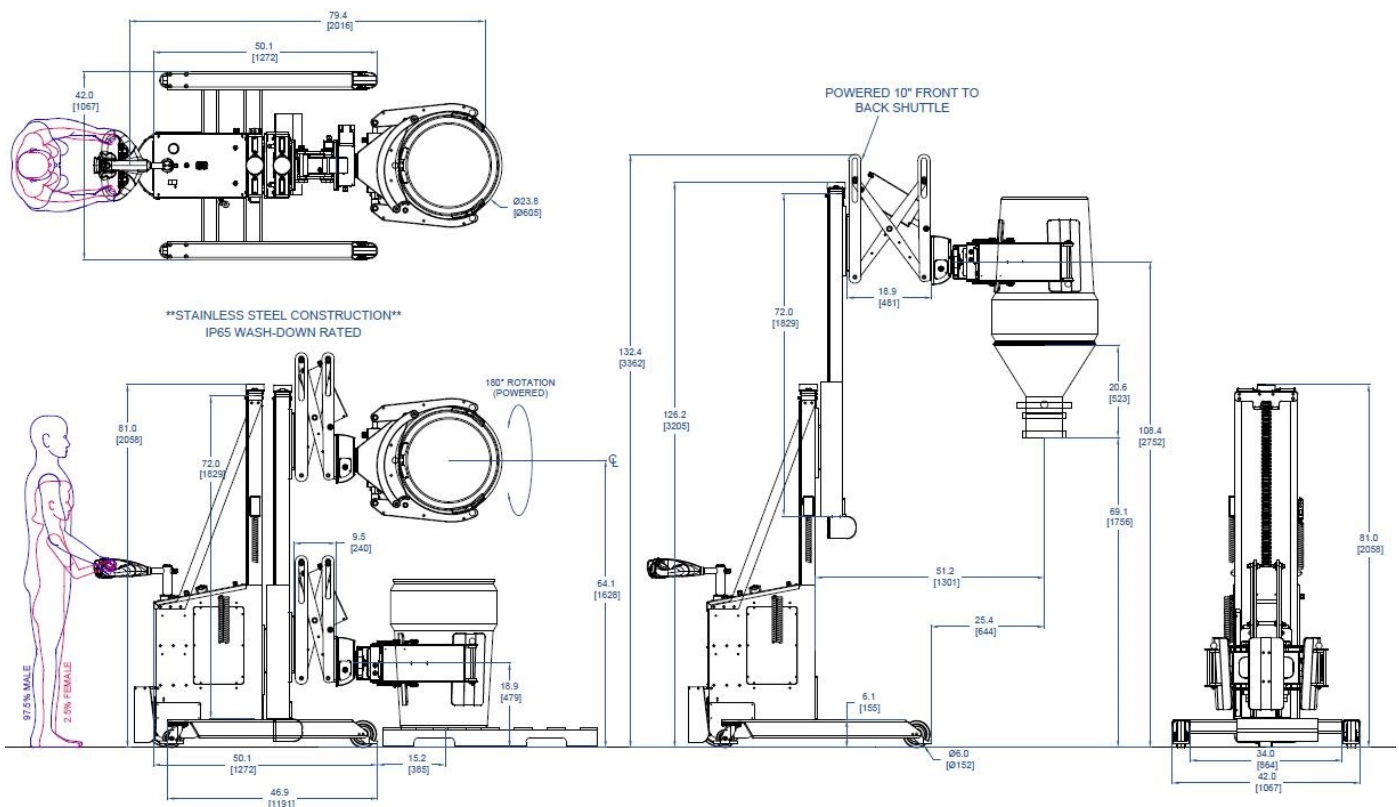

alum-a-lift

13941 Veterans Memorial Hwy
Winston, GA 30187 USA
+1 770 489 0328

GET STARTED AT ALUM-A-LIFT.COM